

# EVERY DENNISON MARKETING SPECIFICATION

© 2019 EVERY DENNISON CORPORATION. ALL RIGHTS RESERVED

## HISTORY

REV.	DATE	DESCRIPTION
A	6-10-20	Initial Creation

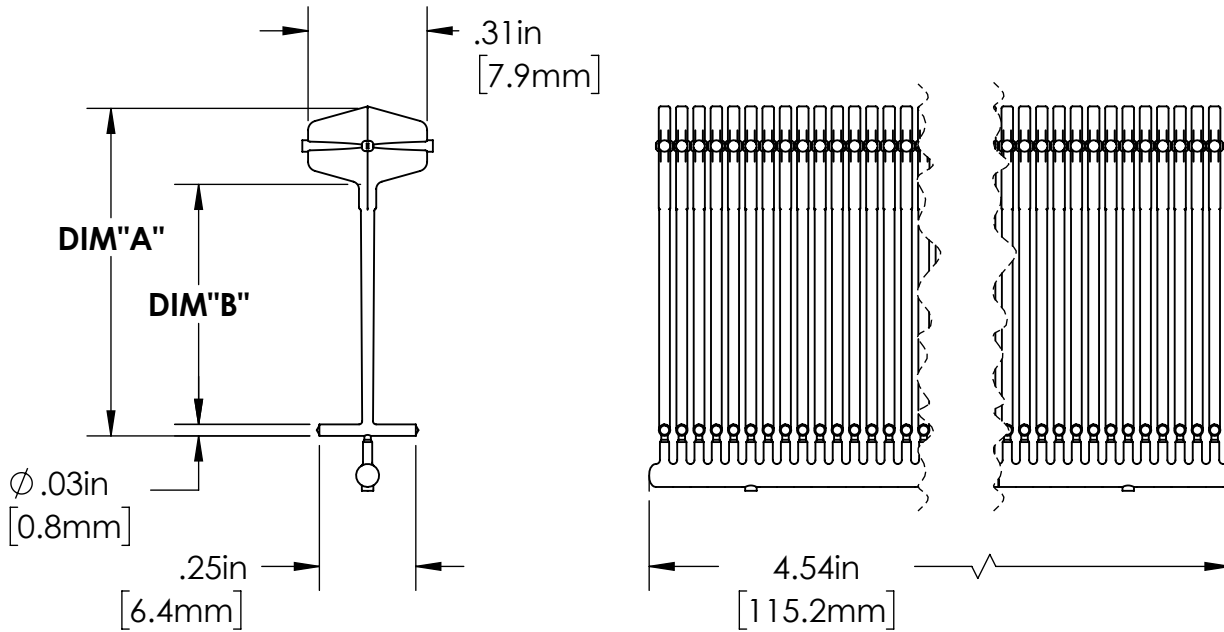

SKU NO	REV	DESCRIPTION	DIM "A"	DIM "B"	WEIGHT
17060-0	A	1/2" [17mm] FF Ecotach™ Bio	.75 [23mm]	.50 [17mm]	.026 grams each
17061-0	A	1" [25mm] FF Ecotach™ Bio	1.25 [32mm]	1.00 [25mm]	.026 grams each
17062-0	A	2" [50mm] FF Ecotach™ Bio	2.25 [57mm]	2.00 [50mm]	.026 grams each
17063-0	A	2-3/4" [70mm] FF Ecotach™ Bio	3.00 [76mm]	2.75 [70mm]	.026 grams each

<b>MINIMUM TENSILE STRENGTH</b>	2.5 LBSF 1.1 KGF
<b>WEIGHT</b>	SEE TABLE
<b>CLIP QUANTITY</b>	100 Fasteners per clip
<b>APPLICATION TOOLS</b>	10312 - Mark III Fine Fabric Pistol-Grip SPU2M02 - Mark II Industrial Fine Fabric - Long Needle SPU2M04 - Mark II Industrial Fine Fabric - Short Needle
<b>PACKAGING</b>	10,000 per carton / 100,000 per case

<b>APPROVALS:</b>	ENG. APPR. <i>Bill Cooper</i> 7-24-20
	Q.A. APPR. <i>Rick Estano</i> 7-24-20



FASTENER DIVISION  
FITCHBURG, MA 01420 U.S.A.  
TEL. 1-800-225-5913  
FAX. 978-353-8157

<b>SPECIFIED TOLERANCES ARE:</b>		<b>MATERIAL</b>	<b>DESCRIPTION</b> Ecotach™ Bio Fine Fabric Clip Fastener	
.XX ± .03 INCHES	.X ± .7 mm	Bio-PP	<b>STOCK NO.</b> See Table	<b>REV.</b> SEE TABLE
.XXX ± .010 INCHES	.XX ± .25 mm	<b>COLOR</b> Natural		
ANGULAR: ± 2°				